

**Part Number: PT546-00140-BU or
PT546-00140
(Base Display Radio)**

Kit Contents

Item #	Quantity Req.	Description
1	1	Receiver Assembly Radio Unit
2	1	Hardware Bag

Hardware Bag Contents

Item #	Quantity Req.	Description
1	8	Bolt (M5×8)

Additional Items Required For Installation

Item #	Quantity Req.	Description
1	1	PT546-00142 or PT546-00143 (Conversion Harness Kit)

Conflicts

13MY Scion Base Audio (PT546-00130)
13MY Scion Premium Audio with Bespoke (powered by Zypr) (PT546-18130)
14MY Scion xB RS 10.0

Recommended Tools

Personal & Vehicle Protection	Notes
Vehicle protection	Blankets
Special Tools	Notes
USB Flash Drive Media	Must contain MP3 songs
Aux port checker	For function checking
Installation Tools	Notes
Panel Clip Removal Tool	e.g. Toyota SST P/N:- 00002-06002-01
Socket Wrench	Open End, 10mm
Socket	10mm
Socket extension	6"
Screwdriver	Phillips, #2
Torque Wrench	5.4 N·m (48 lbf·in)
Masking Tape	(2' wide)
Special Chemicals	Notes
None	

General Applicability

All Scion xB models, includes 10 Year Anniversary Edition.
EXCLUDES: 14MY Scion xB RS 10.0

Recommended Sequence of Application

Item #	Accessory
1	Premium Audio Upgrade (extension box)
2	Base Audio

*Mandatory

Vehicle Service Parts (may be required for reassembly)

Item #	Quantity Req.	Description

Legend



STOP: Damage to the vehicle may occur. Do not proceed until process has been complied with.



OPERATOR SAFETY: Use caution to avoid risk of injury.



CAUTION: A process that must be carefully observed in order to reduce the risk of damage to the accessory/vehicle and to ensure a quality installation.



TOOLS & EQUIPMENT: Used in Figures calls out the specific tools and equipment recommended for this process.



REVISION MARK: This mark highlights a change in installation with respect to previous issue.



SAFETY TORQUE: This mark indicates that torque is related to safety.

Parts Description of Receiver Assembly Radio Unit (PT546-00140 or PT546-00140-BU)



PT546-00140 or PT546-00140-BU

Item #	Parts Name	Parts No.	Qty
1	Receiver Assembly Radio Unit	PT546-00140 or PT546-00140-BU	1

Parts Description of Mounting Kit



Item #	Parts Name	Qty
1	Bolt (M5 x L8)	8

Not included in kit but REQUIRED for installation:
Conversion Harness Kit (PT546-00142 or PT546-00143)

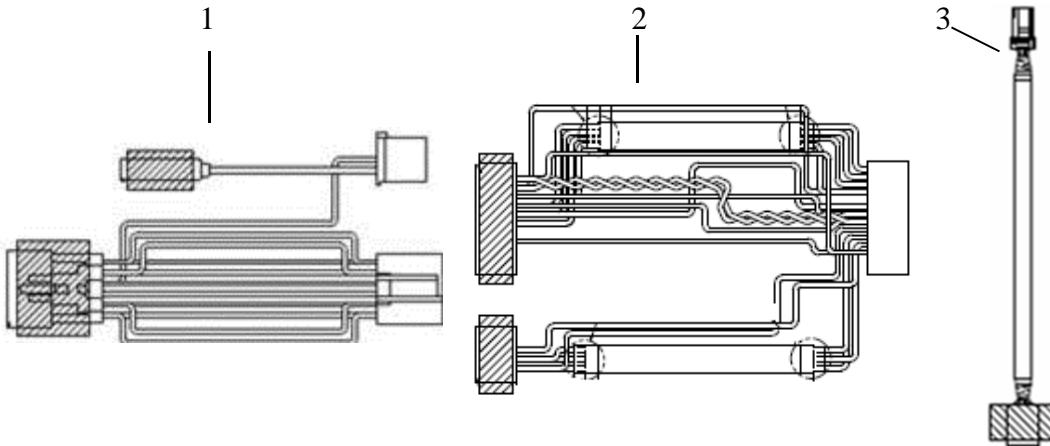

Item #	Parts Name (Conversion Cable)	Parts No.	Qty
1	Antenna + 10 pin adapter	PT546-00142	1
2	Microphone + 28 pin adapter	or	1
3	USB adapter	PT546-00143	1

Care must be taken when installing this accessory to ensure damage does not occur to the vehicle. The installation of this accessory should follow approved guidelines to ensure a quality installation.

These guidelines can be found in the "Accessory Installation Practices" document.

This document covers such items as:-

- Vehicle Protection (use of covers and blankets, cleaning chemicals, etc.).
- Safety (eye protection, rechecking torque procedure, etc.).
- Vehicle Disassembly/Reassembly (panel removal, part storage, etc.).
- Electrical Component Disassembly/Reassembly (battery disconnection, connector removal, etc.).

Please see your Toyota dealer for a copy of this document.

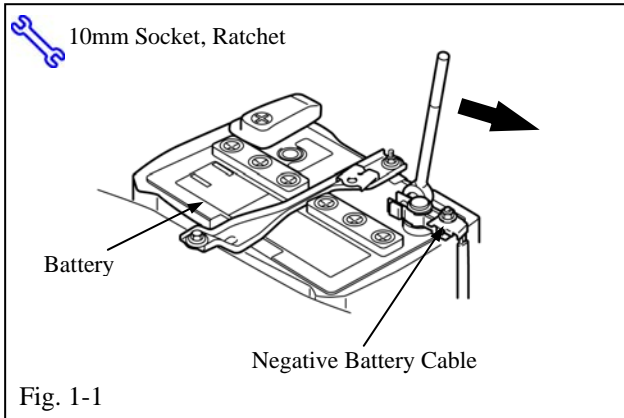

1. Vehicle Protection



(a) Confirm you have all required parts before starting.

(1) Conversion harness kit (PT546-00142) is required.

(b) Protect the fender before starting.

(c) Remove the negative battery cable (Fig. 1-1).



(1) Do not touch the positive terminal with any tool when removing cable.

(d) Check kit contents.

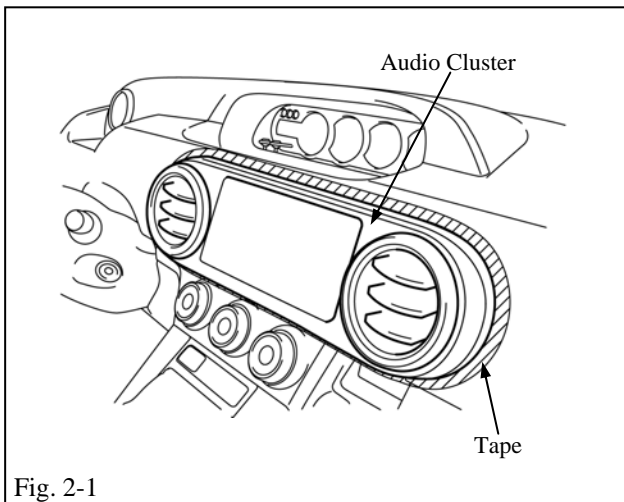

2. Disassembly of Vehicle



NOTE: Place all removed parts on a protected surface.



NOTE: When disconnecting wiring connectors do NOT pull on the wiring, pull on the connector only.



NOTE: Engage the parking brake while working.

(a) Remove the audio cluster.



(1) In order to prevent scratches, apply tape around the audio cluster (shaded areas in the figure) before removing the audio cluster (Fig. 2-1).

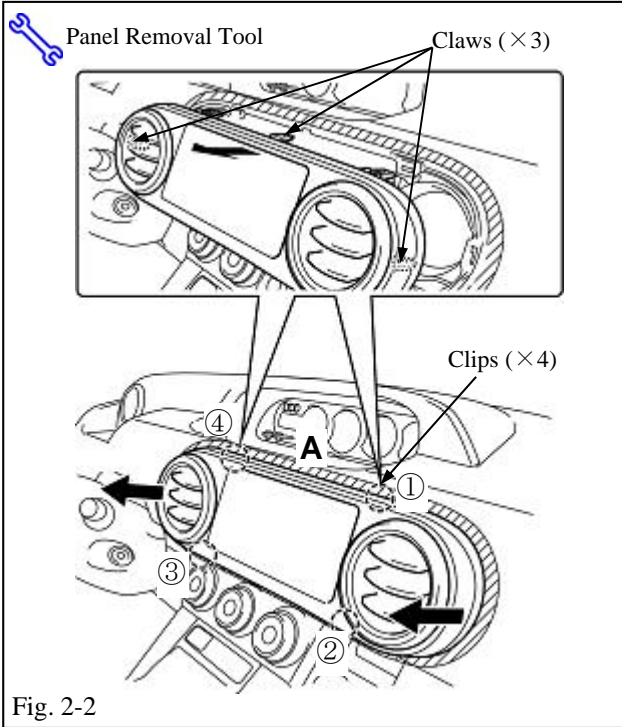

- (2) Insert a removal tool to the section marked "A", and disengage the claws and clips (①) through (④), then remove the audio cluster (Fig. 2-2).

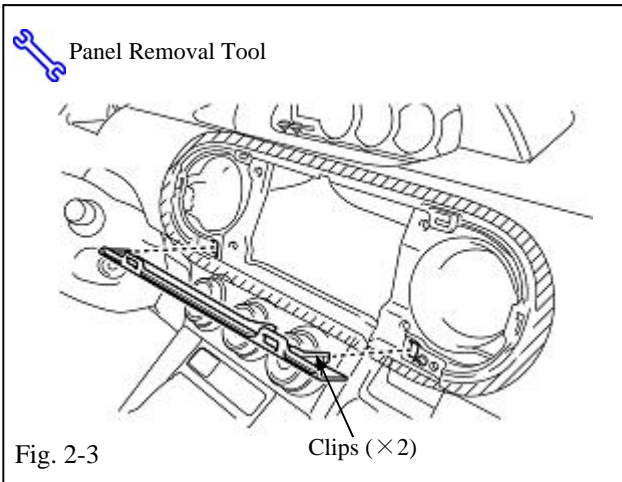

- (3) Disengage the clips (x2) and remove the audio cluster under plate (Fig. 2-3).

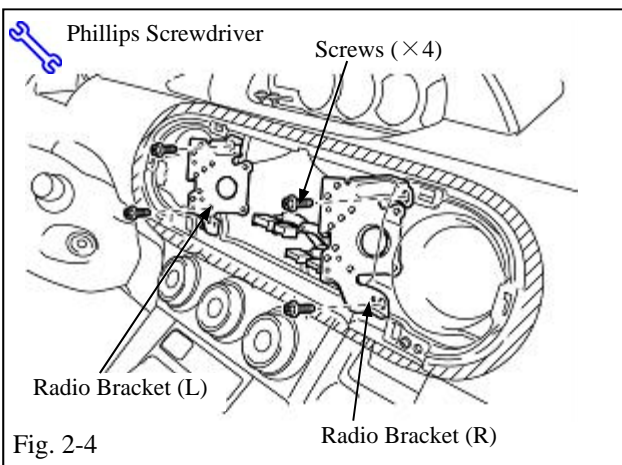

- (b) Remove the 4 bolts to remove the radio brackets (R) and (L) from the interior panel (Fig. 2-4).
- (1) Save the 4 bolts.

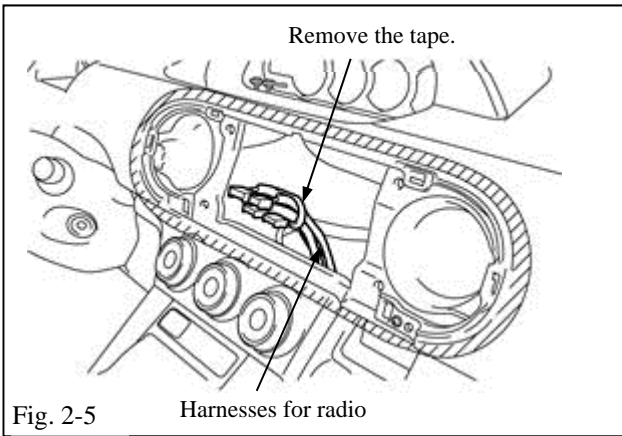

(c) Remove the tape securing the audio harnesses (Fig. 2-5).

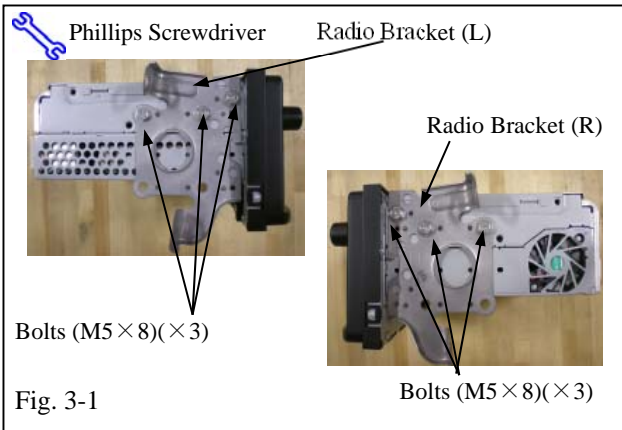

3. Installing the receiver assembly radio unit

(a) Install the radio brackets (R) and (L) on the radio using six of the eight bolts provided in the kit (Fig. 3-1).

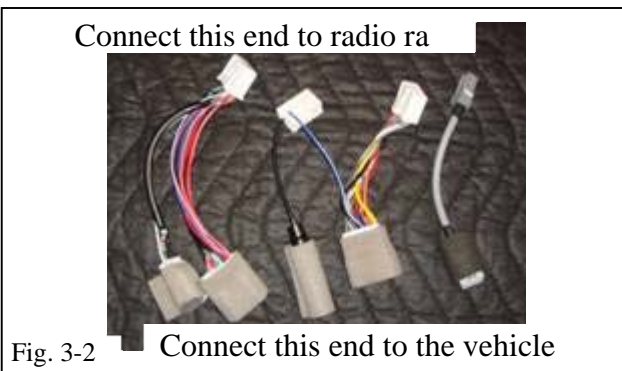

(b) Connect each conversion harness to the vehicle harness. (Fig. 3-2)

⚠ (1) Note: The vehicle harnesses connect to the conversion harness side with the foam.

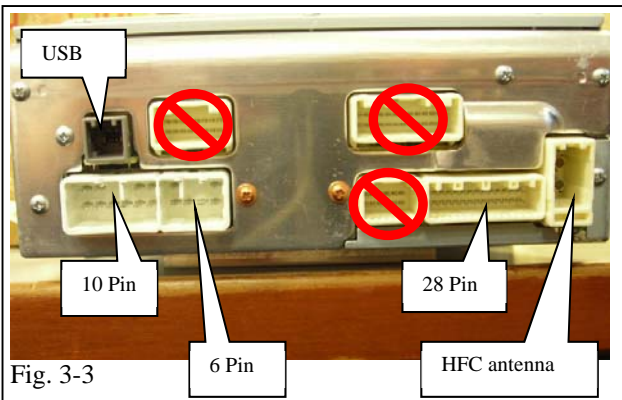

(c) Connect the other side of the four conversion harness connectors and the vehicle 6 pin audio harness connector to the back of the radio. (Fig. 3-3)

⚠ (1) When connecting the connectors to the radio, connect the 10 Pin connector and the HFC antenna connector to the head unit last.

(2) There should be a total of five connectors connected to the radio.

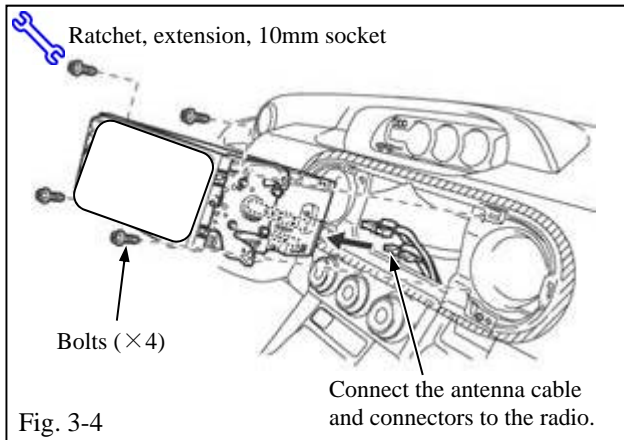

(d) Install the radio to the instrument panel.



(1) Guide the harnesses back and downward into the radio opening to ease the installation of the radio.

(2) Fasten the radio brackets with the four bolts removed in Step 2(b). (Fig. 3-4)

4. USB function check

- (a) Temporarily connect negative battery cable.
- (b) If required, install the short pin.
- (c) Turn the ignition switch to the ACC position.
- (d) Connect the USB flash drive media to the vehicle's USB/AUX connector. (Fig. 4-1)
- (e) Select USB mode by pressing the "source" button on the touch display screen, then selecting USB mode. (Fig. 4-2)
- (f) Confirm song plays.
- (g) Remove flash drive from USB connector.

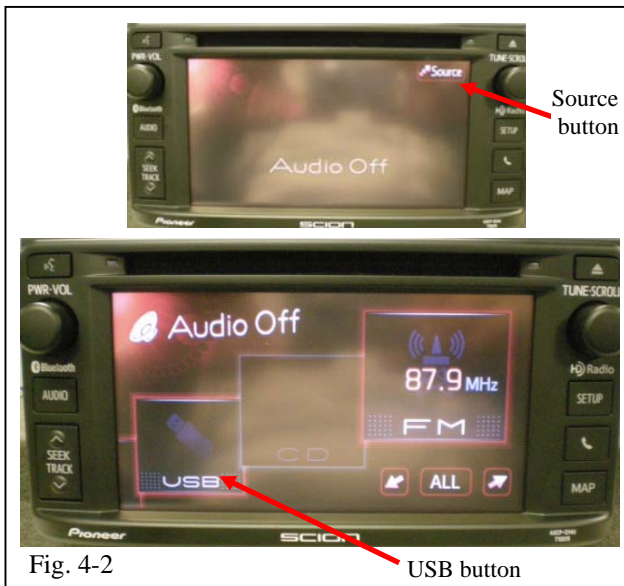

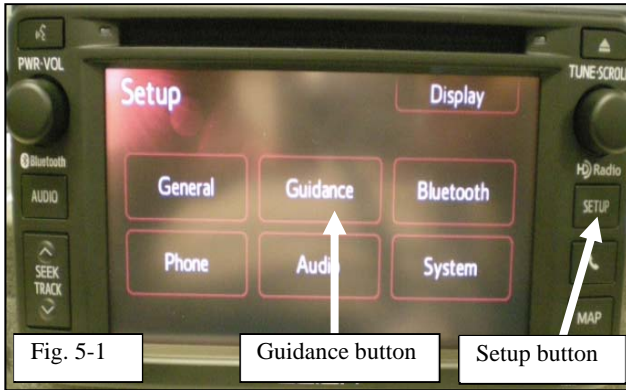

Fig. 5-1

Guidance button

Setup button

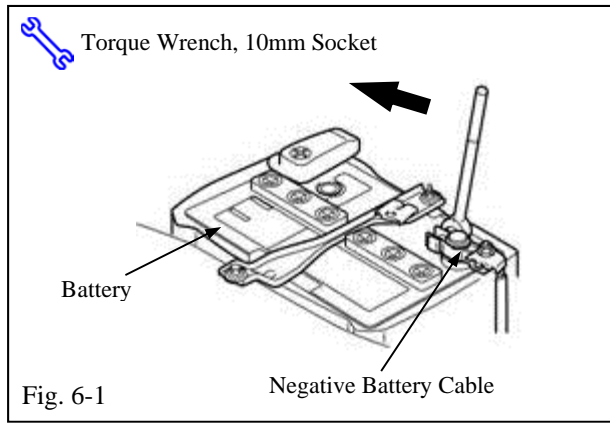

Fig. 6-1

Negative Battery Cable

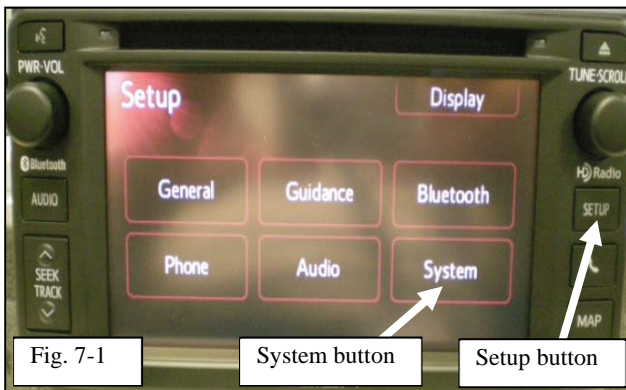

Fig. 7-1

System button

Setup button

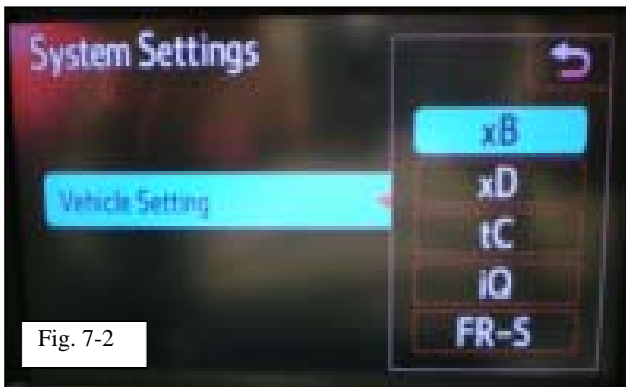

Fig. 7-2

5. BT microphone check

- (a) Press the setup menu button.
- (b) If the guidance menu is available, the microphone is connected. (Fig. 5-1)
- (c) Turn the ignition key off.
- (d) Remove the negative battery cable.

6. Completing the installation

- (a) Complete the reassembly of the vehicle.
 - ⚠ (1) Reconnect any disconnected connectors.
 - ⚠ (2) Verify the panels fit together properly with no uneven gaps between them.
- (b) Clean up and remove any trash.
- (c) Reconnect the vehicle's negative battery cable.
 - (1) Position negative cable at original factory position. (Fig. 6-1).
 - (2) Tighten the nut to 5.4 N•m (48 lbf•in).
 - ⚠ **Torque: 5.4 N•m (48 lbf•in)**
 - ⊕ (3) Do not touch the positive terminal with any tool when replacing the cable.
- (d) Perform functional checks.
- (e) If required, replace the short pin to its original position.

7. For DIO installations, set the vehicle sound setting to the correct vehicle.

- (a) Press the setup menu button. (Fig. 7-1)
- (b) Press the system button. (Fig. 7-1)
- (c) Under vehicle setting, select "xB" and press save. (Fig. 7-2)

Checklist – these points **MUST** be checked to ensure a quality installation.

Check: _____	Look For: _____
<p><u>Accessory Function Checks</u></p> <ul style="list-style-type: none"> <input type="checkbox"/> Insert CD audio disc and confirm operation. <input type="checkbox"/> Turn radio on and confirm operation. <input type="checkbox"/> Antenna is functional. <input type="checkbox"/> Fade <input type="checkbox"/> Balance <input type="checkbox"/> Illumination <input type="checkbox"/> AUX port 	<ul style="list-style-type: none"> Functioning CD player Radio functions properly. Reception of AM/FM stations Functioning fade, front to rear speakers Functioning balance, left to right speakers Illumination should function properly AUX port should function properly
<p><u>Vehicle Function Checks</u></p> <ul style="list-style-type: none"> <input type="checkbox"/> Steering Wheel audio controls <input type="checkbox"/> Rheostat/Dimmer <input type="checkbox"/> Electroluminescent panel (if equipped) 	<ul style="list-style-type: none"> Functioning audio controls Functioning dimmer control EL panel should function properly
<p><u>Vehicle Appearance Checks</u></p> <ul style="list-style-type: none"> <input type="checkbox"/> Visual Inspection (After accessory installation and removal of protective covers(s), perform visual inspection.) 	<p>Ensure no damage (including scuffs and scratches) was caused during the installation process. Panels should fit and align properly.</p> <p>(For PPO installations, refer to TMS Accessory Quality Shipping Standard)</p>